



**BULLARD
BOLLARDS**
Think Bollard Think Bullard



DELIA (SINGLE EMISSION)

K12
RATING

ILLUMINATED SECURITY & SAFETY BOLLARDS



Fixture Type:

Project Name:

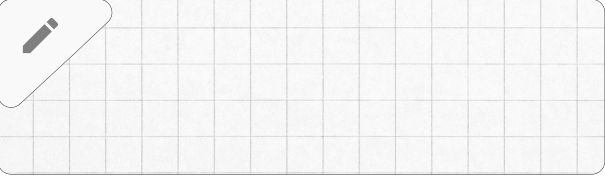

General Information:

DELIA (Single Emission)

With a focused, directional light output, DELIA Single Emission supports safer movement by enhancing visibility where it's needed most. Its refined form provides dependable impact resistance while maintaining a clean architectural presence.

Flexible finishes and mounting options allow it to integrate naturally into a wide range of environments, balancing safety, performance, and design.

Applications: pathways, commercial developments, controlled access areas

Fixture Type:

Illuminated Security & Safety Bollard

Lighting:

LED

Voltage:

110-277V

Material:

Stainless Steel

Driver Position:

Integral

IP Rating:

IP 65

Appliance Class:

I

Lighting Distribution:

360°

Warranty:

LED lighting products are warranted for 5 years.

Main Features:

High visual comfort

Available in a wide range of finishes

Functional and minimalistic design

Shock-resistant construction

Operating Temperature: -104°F to +140°F.



Due to the dynamic nature of lighting products and the associated technologies, luminaire data on all specification sheets is subject to change at the discretion of Gordon Bullard LLC and associated companies.

THINK BOLLARD - THINK BULLARD

sales@gordonbullard.com / www.bullardbollards.com / 1-877-964-4646

991 South Gull Lake Dr Richland, MI 49083 USA



Fixture Type:

Project Name:

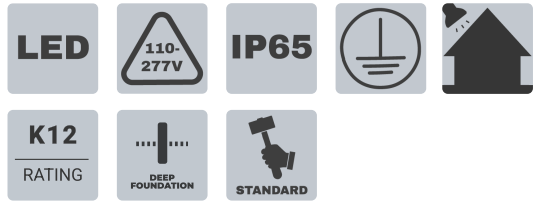
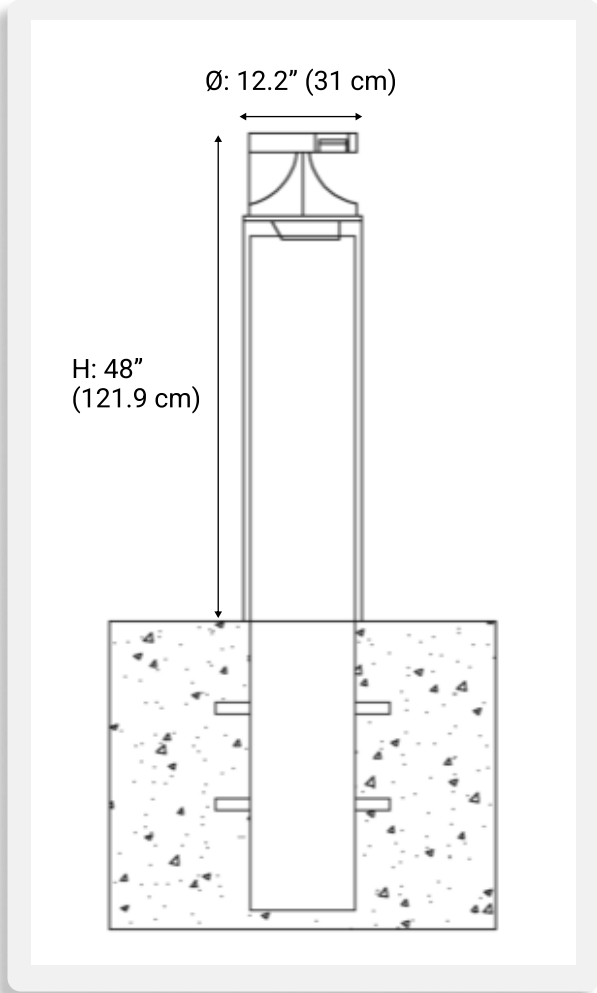

HOW TO ORDER:

CODE:

CODE EXAMPLE:
BB-DLSN-GLC-K12-LSB9-FC-K30-DIM-BL

BB-DLSN-GLC-K12-LSB9-FC-K30-DIM-BL

1 DIMENSIONS:

Diameter - Ø: 12.2" (31 cm)
Overall Height - H: 48" (121.9 cm)

2 LIGHT SOURCE OUTPUT BOLLARD:

- LSB6 6 W / 396 lm
- LSB9 9 W / 580 lm
- LSB10 10 W / 590 lm
- LSB15 15 W / 880 lm
- LSB20 20 W / 1280 lm
- LSBC Custom Lumen packages on request*

3 LENS:

- SC Standard Clear
- FC Frosted Acrylic

4 CCT:

- K22 2200K
- K30 3000K
- K35 3500K
- K40 4000K
- K50 5000K

5 DIMMING OPTIONS:

- NON NON-Dimmable
- DIM 0-10V

6 FINISH OPTIONS:

- WH White (RAL 9010)
- BL Black (RAL 9005)
- BR Bronze (RAL 8004)
- LG Light Grey (RAL 7047)
- DK Dark Grey (RAL 7021)
- BSS Brushed Stainless Steel
- CUS Custom on request*



Due to the dynamic nature of lighting products and the associated technologies, luminaire data on all specification sheets is subject to change at the discretion of Gordon Bullard LLC and associated companies.

THINK BOLLARD - THINK BULLARD

sales@gordonbullard.com / www.bullardbollards.com / 1-877-964-4646
991 South Gull Lake Dr Richland, MI 49083 USA

DOS K12 RATING EXPLAINED

DOS K-ratings are a legacy U.S. Department of State crash-testing classification system used to define the performance of security barriers (such as bollards) against vehicle impact. The rating is based on a standardized test involving a 15,000 lb vehicle impacting at defined speeds—K4 (30 mph), K8 (40 mph), and K12 (50 km/h ≈ 50 mph)—with performance measured by how effectively the barrier stops the vehicle and limits penetration beyond the barrier line.



DOS K12

- **Vehicle weight:** 15,000 lbs
- **Impact speed:** (50 mph)
- **Vehicle type:** medium-duty truck
- **Penetration:** 1 meter or less (L3)
- **Test standard:** U.S. Department of State (DOS) crash test protocol

FOUNDATION OPTIONS EXPLAINED

Understanding foundation type and depth is critical to ensure the bollard performs as designed under impact. Improper installation can significantly reduce crash-rating effectiveness and compromise site safety.



Deep Foundation

- **Excavation:** 47.25 in (1200 mm) depth
- **Reinforcement:** Rebar cage (#5 / #8)
- **Installation:** Bollard embedded and fully encased in concrete
- **Function:** Transfers impact load into deep concrete mass



Due to the dynamic nature of lighting products and the associated technologies, luminaire data on all specification sheets is subject to change at the discretion of Gordon Bullard LLC and associated companies.

THINK BOLLARD - THINK BULLARD

sales@gordonbullard.com / www.bullardbollards.com / 1-877-964-4646

991 South Gull Lake Dr Richland, MI 49083 USA