



**BULLARD
BOLLARDS**
Think Bollard Think Bullard

INSTALLATION INSTRUCTION

SCUBO C SMALL

INSTALLATION TYPE:
SURFACE MOUNTED
WALL LUMINAIRES

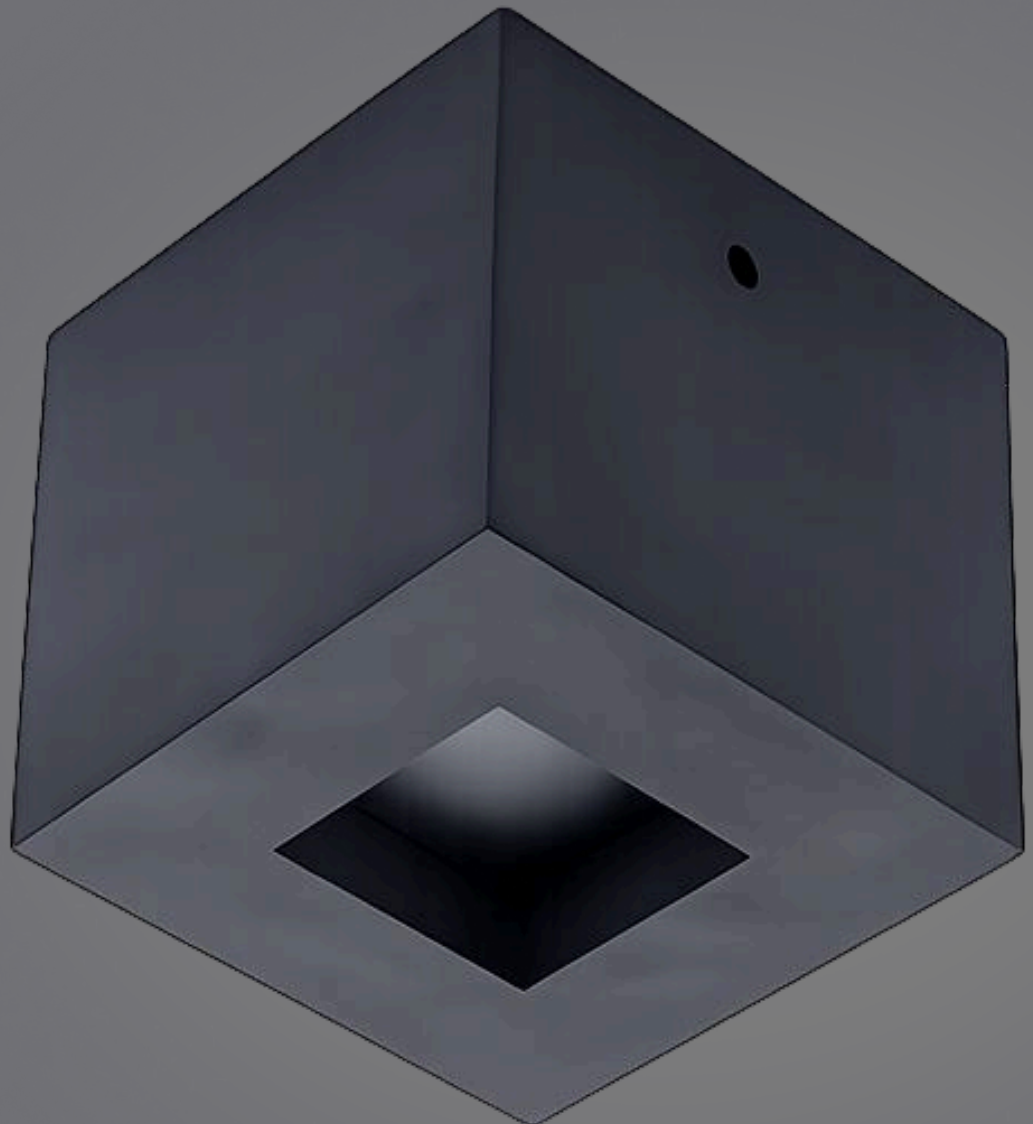

03/03/2026

ⓘ	SILOS 1203	SILOS PLISSE 1204	SCUBO C SMALL 1094B	All technical specs can be found in the internal technical label. The article contains a light source of class F.
💡	LED 4W	LED 4W	LED 4W	
CL				
⚡	24V	24V	24V	
IP	IP65	IP65	IP65	
Lb	4.4	5.7	3.1	

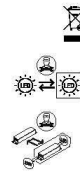

		x1	⚠ Connection terminal not included. Do not stress the cable by pulling. IP code of the connection must be equal or higher than the article's. For the installation qualified personnel may be required. Do not make any changes to the article in any way. The cable can be substituted only by the manufacturer. In the event that the manufacturer accept the return of the article to verify it's operation the article must not be disassembled.	
		x2		
		x2		
		x2		
		x2		
		x1		

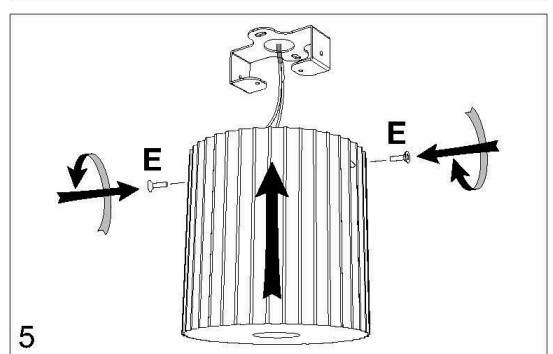
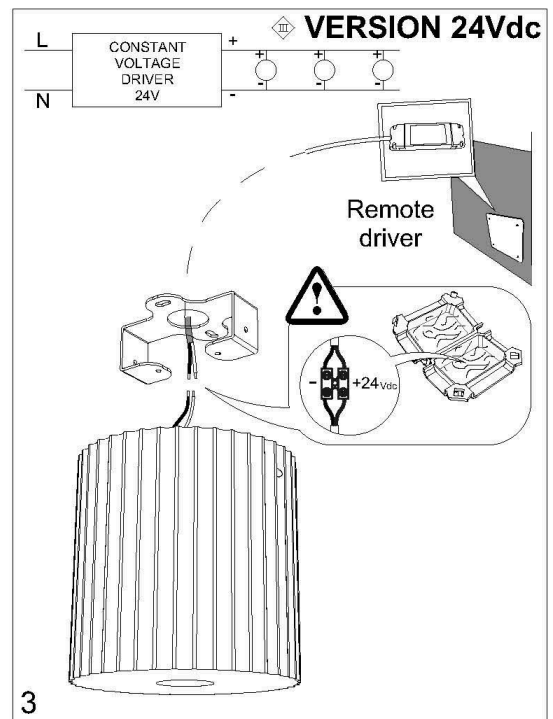
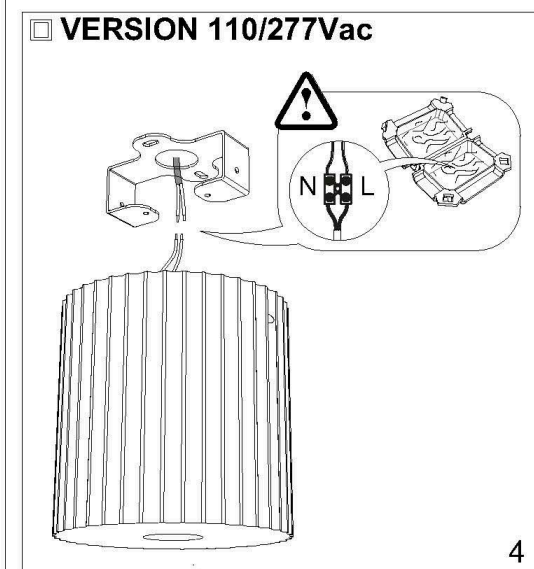
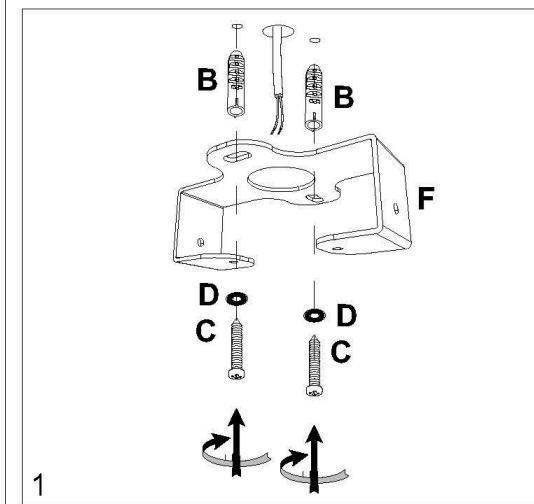

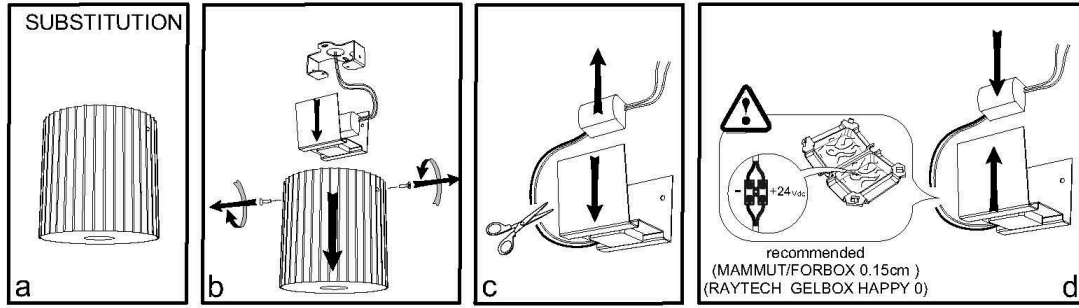

sales@gordonbullard.com
www.bullardbollards.com
1 877-964-4646



991 South Gull Lake Dr.
Richland, MI 49083
USA

IMPORTANT

- To ensure equipment safety you must carefully follow the instructions below. This leaflet must be kept handy by personnel entrusted with all ordinary and extraordinary maintenance.
- Before any installation or maintenance operation on the bulb, make sure it is disconnected from power.
- Fit the correct bulbs, according to the type and power indicated on the lamp data label.
- Make sure the lamp technical features are compatible with the use you are going to make of it.
- Should you have any doubt, refer to the dealer or ask an electrician.
- When connecting to the mains, follow the correct colour code for power cables: (N) blue, (L) brown or black and, only for class I equipment, (T) yellow/green.
- When lamps are to be fitted to the wall directly through their ceramic parts, fasten the fixing screws lightly, to avoid breaking the ceramic.
- To clean the lamp on the outside, use a soft cloth, possibly wet. Do not use solvents or abrasive products. No liquid must get in contact with the lamp interior parts.
- Do not touch the equipment with dirty hands.



= Class I equipment, must be connected to an earth terminal.



= Double insulated lamp, does not need earthing.



= Electrical equipment in class III, electrical safety guaranteed by low voltage tension, does not require grounding



= Minimum distance to be observed from all lit up objects.

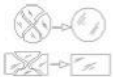

= Replace immediately the safety glass, if damaged, with the original part.



= The lamp uses low pressure bulbs, and needs no protection glass.