



**BULLARD
BOLLARDS**
Think Bollard Think Bullard



BUNNY

PU40
RATING

ILLUMINATED **SECURITY & SAFETY BOLLARDS**

Fixture Type:

Project Name:

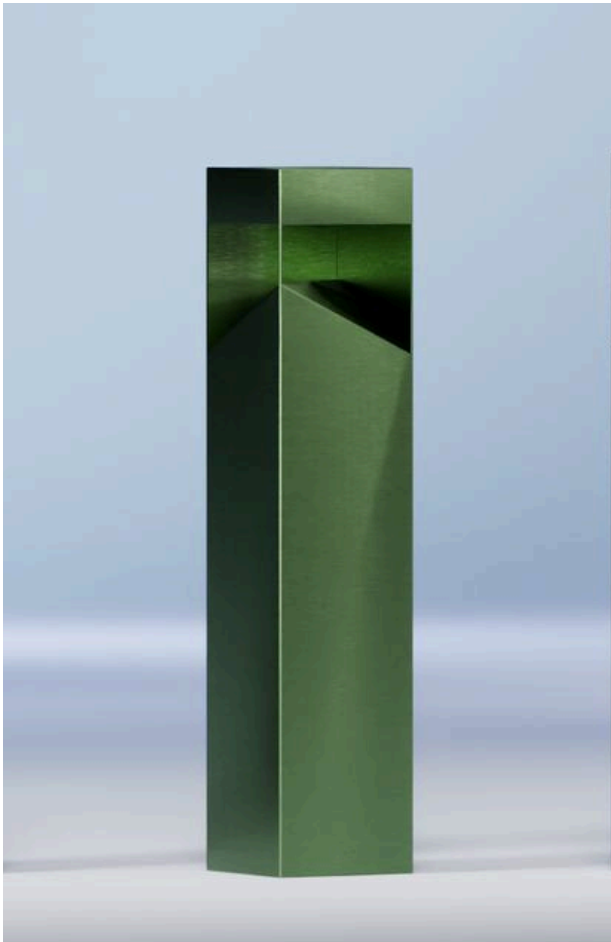

General Information:

A compact, architectural solution for safer environments, BUNNY combines defined form with integrated illumination to support both protection and visibility. Its square-profile design establishes clear boundaries, helping guide movement and reduce risk in pedestrian-focused spaces.

Constructed from durable materials, it withstands demanding conditions while maintaining consistent performance. Integrated LED lighting enhances nighttime clarity, improving spatial awareness without visual disruption. Customizable sizes, finishes, and mounting options allow seamless integration into a wide range of settings.

Designed for flexibility and reliability, BUNNY delivers dependable safety while complementing modern landscapes.

Applications: urban environments, pedestrian pathways, commercial spaces

Fixture Type:

Illuminated Security & Safety Bollard

Lighting:

LED

Voltage:

110-277V

Material:

Stainless Steel, Acrylic

Driver Position:

Integral

IP Rating:

IP 65

Appliance Class:

I

Warranty:

LED lighting products are warranted for 5 years.



Due to the dynamic nature of lighting products and the associated technologies, luminaire data on all specification sheets is subject to change at the discretion of Gordon Bullard LLC and associated companies.

THINK BOLLARD - THINK BULLARD

sales@gordonbullard.com / www.bullardbollards.com / 1-877-964-4646
991 South Gull Lake Dr Richland, MI 49083 USA



Fixture Type:

Project Name:

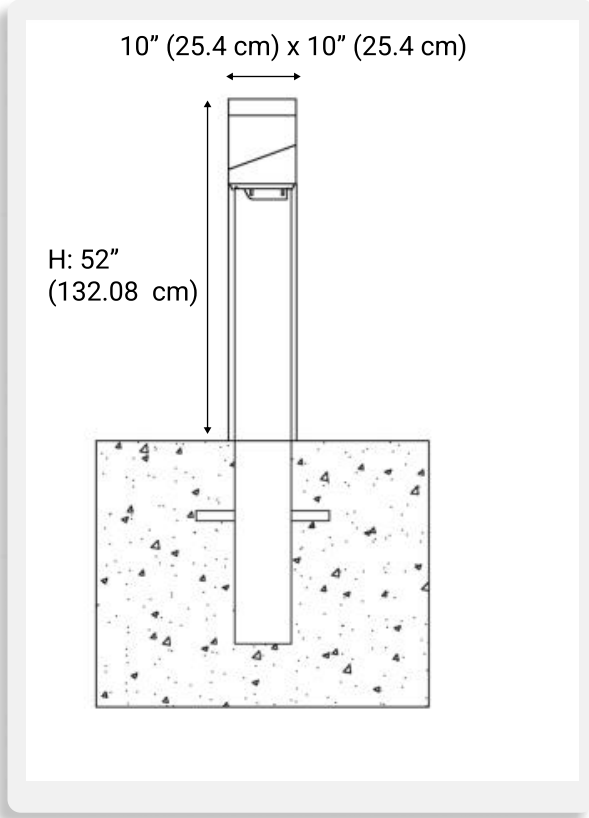

HOW TO ORDER:

CODE:

CODE EXAMPLE:
BB-BNN-GLC-PU40-LSB20-K30-DIM-WH

**BB-BNN-GLC-
PU40-LSB20-
K30-DIM-WH**

1 **DIMENSIONS:**

Length x Width - LxW: 10" (25.4 cm) x 10" (25.4 cm)
Overall Height - H: 52" (132.08 cm)
-Cus Custom height on request*

2 **LIGHT SOURCE OUTPUT BOLLARD:**

-LSB20 20 W / 1800 lm / CRI 90
-LSBC Custom Lumen packages on request*

3 **LIGHTING DISTRIBUTION:**

180°

4 **CCT:**

-K30 3000K
-K35 3500K
-K40 4000K

5 **DIMMING OPTIONS:**

-NON NON-Dimmable
-DIM 0-10V

6 **FINISH OPTIONS:**

-WH White (RAL 9010)
-BL Black (RAL 9005)
-BR Bronze (RAL 8004)
-LG Light Grey (RAL 7047)
-DK Dark Grey (RAL 7021)
-BSS Brushed Stainless Steel
-CUS Custom on request*



Due to the dynamic nature of lighting products and the associated technologies, luminaire data on all specification sheets is subject to change at the discretion of Gordon Bullard LLC and associated companies.

THINK BOLLARD - THINK BULLARD

sales@gordonbullard.com / www.bullardbollards.com / 1-877-964-4646
991 South Gull Lake Dr Richland, MI 49083 USA

ASTM CRASH RATINGS EXPLAINED

ASTM crash ratings (ASTM F2656) are a U.S. standard used to classify the performance of vehicle security barriers based on their ability to stop a 15,000 lb (6,800 kg) truck at defined impact speeds. The rating combines impact speed—M30 (30 mph), M40 (40 mph), or M50 (50 mph)—with a penetration level (P1, P2, P3), indicating how far the vehicle travels past the barrier after impact, providing a clear benchmark for selecting appropriate protection against specific vehicle-borne threats.

THE RATING CATEGORIES BREAK DOWN AS FOLLOWS:

SC  (SC) Small Passenger Car

- Vehicle weight: 2,430 lbs
- Speed ratings: SC40 (40 mph), SC50 (50 mph), SC60 (60 mph)
- Use case: Low-mass vehicle threats; urban or light-security environments

PU  (PU) Pickup Truck

- Vehicle weight: 5,070 lbs
- Speed ratings: PU40 (40 mph), PU50 (50 mph), PU60 (60 mph)
- Use case: Mid-range threats; commercial zones, parking perimeters

M  (M) Medium-Duty Truck

- Vehicle weight: 15,000 lbs
- Speed ratings: M30 (30 mph), M40 (40 mph), M50 (50 mph)
- Use case: Elevated risk scenarios; logistics hubs, public infrastructure



Due to the dynamic nature of lighting products and the associated technologies, luminaire data on all specification sheets is subject to change at the discretion of Gordon Bullard LLC and associated companies.

THINK BOLLARD - THINK BULLARD

sales@gordonbullard.com / www.bullardbollards.com / 1-877-964-4646

991 South Gull Lake Dr Richland, MI 49083 USA

FOUNDATION OPTIONS EXPLAINED

Understanding foundation type and depth is critical to ensure the bollard performs as designed under impact. Improper installation can significantly reduce crash-rating effectiveness and compromise site safety.



Deep Foundation

- **Excavation:** 47.25 in (1200 mm) depth
- **Reinforcement:** Rebar cage (#5 / #8)
- **Installation:** Bollard embedded and fully encased in concrete
- **Function:** Transfers impact load into deep concrete mass



Due to the dynamic nature of lighting products and the associated technologies, luminaire data on all specification sheets is subject to change at the discretion of Gordon Bullard LLC and associated companies.

THINK BOLLARD - THINK BULLARD

sales@gordonbullard.com / www.bullardbollards.com / 1-877-964-4646

991 South Gull Lake Dr Richland, MI 49083 USA